

# 1 Series

Capacity up to 75 lbs each



## Features

- Zinc plated finish is attractive and durable
- Full double ball hardened raceways for better performance and greater durability
- 5/16" shouldered axle with 1/4" nut
- "Colson 45" multi-temp grease lubricates in extreme hot and cold temperatures

## Standard Mounting

- Spring grip on top of stem holds caster firmly in place
- **Stem Size:** 7/16" x 1 29/32" long with grip ring



## Standard Dimensions

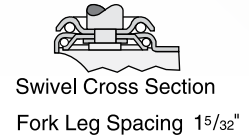
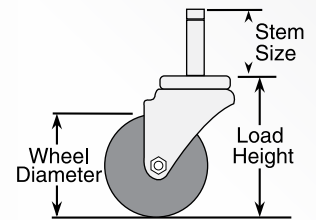

## Colson 1 Series Casters • Grip Ring Stem • Capacity to 75 lbs each

Wheel Dia.	Tread Width	Capacity Each (Pounds)	Wheel Descriptions	Wheel Bearing	Stem Caster Models	Load Height	Swivel Radius	Weight (Pounds)
1 5/8"	7/8"	60	Performa Rubber	Delrin	1.01651.441	2 1/2"	1 3/4"	1/2
		75	Polyolefin	Delrin	1.01651.52	2 1/2"	1 3/4"	1/2
2"	7/8"	75	Performa Rubber	Delrin	1.02251.441	2 11/16"	1 15/16"	1/2
			Polyolefin	Delrin	1.02251.52	2 11/16"	1 15/16"	1/2
			Cushion Rubber	Ball	1.02251.45	2 11/16"	1 15/16"	5/8
			Hard Rubber	Ball	1.02251.55	2 11/16"	1 15/16"	5/8
3"	7/8"	75	Performa Rubber	Delrin	1.03051.441	3 13/16"	2 9/16"	3/4
			Polyurethane HI-TECH	Delrin	1.03051.91	3 13/16"	2 9/16"	3/4
			Polyolefin	Delrin	1.03051.53	3 13/16"	2 9/16"	3/4

## Caster Brake



**Side Lock**  
(See page 96) Available on all 3" models. Field installable (Specify **BRK3**; Example: 1.03051.53 BRK3).

## Fork Options

**NSF Listed for Food Service Industry**  
All models except thread guards.

### Forks Only

To order caster forks only use 1st 6 digits of model numbers (Example: 1.01651).

## Wheel Selection

Performa Flat Tread



See the Performa Advantage on Page 67.

Polyolefin



Polyurethane HI-TECH



Cushion Rubber



Hard Rubber



## Wheel Option

### Thread Guards

(See page 108) Available on all 3" models. Brake & NSF options cannot be used with thread guards (Specify **TG1** for metal; Example: 1.01651.441 TG1).

## Mounting Options

**Standard Mounting (no code necessary):**  
7/16" x 1 29/32" long with grip ring.

**MTG1:** 3/8" x 1 9/16" long

**MTG2:** 7/16" x 1 9/16" long

**MTG50:** 7/16" x 1" long

**MTG51:** 7/16" x 1 29/32" long less grip ring

**MTG57:** 1/2" x 4 1/2" (ladder caster stem)

To order optional mounting, add mounting code to Stem Caster Models number (Example: 1.01651.441 MTG1).



# 1 Series

Capacity up to **145 lbs each**



## Standard Dimensions

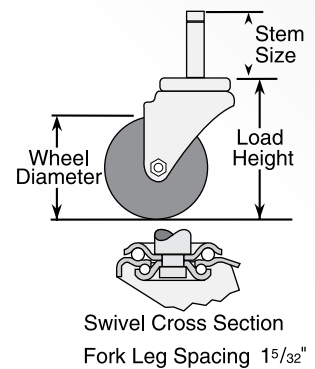

### Features

- Zinc plated finish is attractive and durable
- Full double ball hardened raceways for better performance and greater durability
- 5/16" shouldered axle with 1/4" nut
- "Colson 45" multi-temp grease lubricates in extreme hot and cold temperatures

### Standard Mounting

- Spring grip on top of stem holds caster firmly in place
- Stem Size: 7/16" x 1 29/32" long with grip ring

## Colson 1 Series Casters • Grip Ring Stem • Capacity to 145 lbs each

Wheel Dia.	Tread Width	Capacity Each (Pounds)	Wheel Descriptions	Wheel Bearing	Stem Caster Models	Load Height	Swivel Radius	Weight (Pounds)
3"	7/8"	100	Polyurethane HI-TECH	Delrin	1.03351.91	33/4"	213/16"	1
		125	Performa Rubber	Delrin	1.03351.441	33/4"	213/16"	11/8
			Polyolefin	Delrin	1.03351.53	33/4"	213/16"	11/8
4"	7/8"	125	Polyurethane HI-TECH	Delrin	1.04351.91	43/4"	37/16"	11/8
		135	Performa Rubber	Delrin	1.04351.441	43/4"	37/16"	13/8
			Polyolefin	Delrin	1.04351.53	43/4"	37/16"	13/8
5"	7/8"	140	Polyurethane HI-TECH	Delrin	1.05351.91	53/4"	41/16"	11/4
		145	Performa Rubber	Delrin	1.05351.441	53/4"	41/16"	15/8
			Polyolefin	Delrin	1.05351.53	53/4"	41/16"	11/8

### Caster Brake



**Side Lock** (See page 96)  
Available on all models. Field installable (Specify **BRK3**; Example: 1.03351.91 BRK3).

### Fork Options

**NSF Listed for Food Service Industry**  
All models except thread guards.

#### Forks Only

To order caster forks only use 1st 6 digits of model numbers (Example: 1.03351).

### Wheel Selection

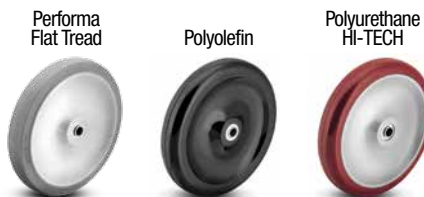

### Wheel Option

**Thread Guards**  
(See page 108) Available on all 3" models. Brake & NSF options cannot be used with thread guards (Specify **TG1** for metal; Example: 1.03351.91 TG1).

### Mounting Options

**Standard Mounting (no code necessary):**  
7/16" x 1 29/32" long with grip ring **no** plastic adapter.

**MTG2:** 7/16" x 1 1/2" long

**MTG51:** 7/16" x 1 29/32" long **less** grip ring

To order optional mounting, add mounting code to Stem Caster Model number (Example: 1.03367.91 MTG51).

### Plastic Adapters

Snaps in place to reduce distortion and damage to furniture and equipment tubing.

Plastic adapters are non-conductive. To order, add plastic adapter mounting code from below to Stem Caster Model number (Example: 1.03351.91 MTG53).

**MTG53:** (No. 50810): Fits 7/8" x 18 ga. wall round tubing or any I.D. from 3/4" to 51/64".

**MTG55:** (No. 50865): Fits 1" x 14 ga. wall round tubing or any I.D. from 53/64" to 55/64".

**MTG56:** (No. 50916): Fits 1" x 16 ga. wall round tubing or any I.D. from 57/64" to 29/32".

