

2 Series

Capacity up to **250 lbs each**



Features

- Zinc plated finish is attractive and durable
- Available with top lock brake
- 3/8" Bolted Axle
- Compatible with many different nationally branded convertible hand trucks
- Features polyolefin thread guard

Standard Mounting

1" x 2 1/2" long stem with one mounting hole, .40" dia.



Standard Dimensions

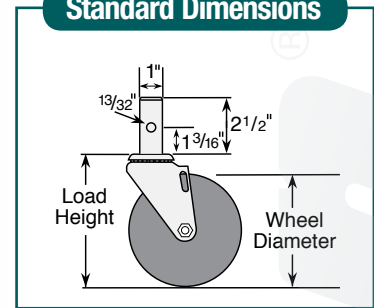

Colson 2 Series Casters • Convertible Hand Truck • Capacity to 250 lbs

Wheel Dia.	Tread Width	Capacity Each (Pounds)	Wheel Description	Wheel Bearing	Stem Caster Model	Load Height	Swivel Radius	Weight (Pounds)
5"	1 5/16"	250	TPR (Round)	Centered Precision Ball	2.05551.568	5 7/8"	3 13/16"	2

Caster Brake



Top Lock
Brake is not field installable (Specify **BRK1**; Example: 2.05551.568 BRK1).

Wheel Option

Thread Guards
Standard polyolefin thread guard.